

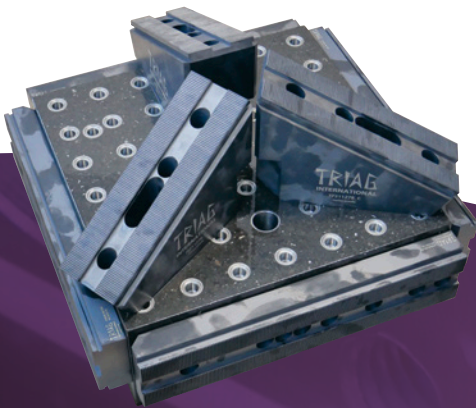

TRIAG
INTERNATIONAL

swissMODULAR

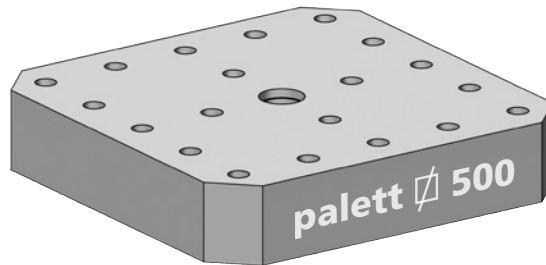
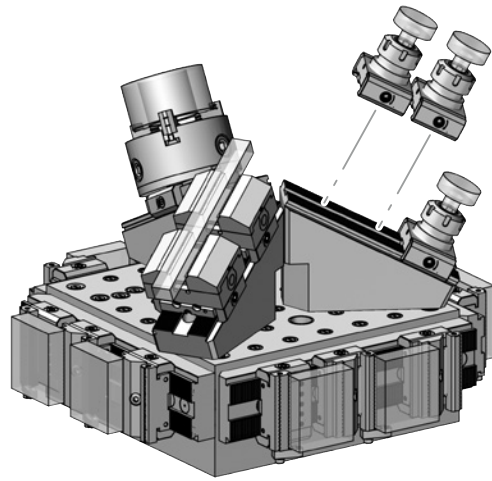

Spannlösungen für Mazak
Workholding solutions for Mazak

HCR5000S



3D Modulares Spannsystem Modular workholding system

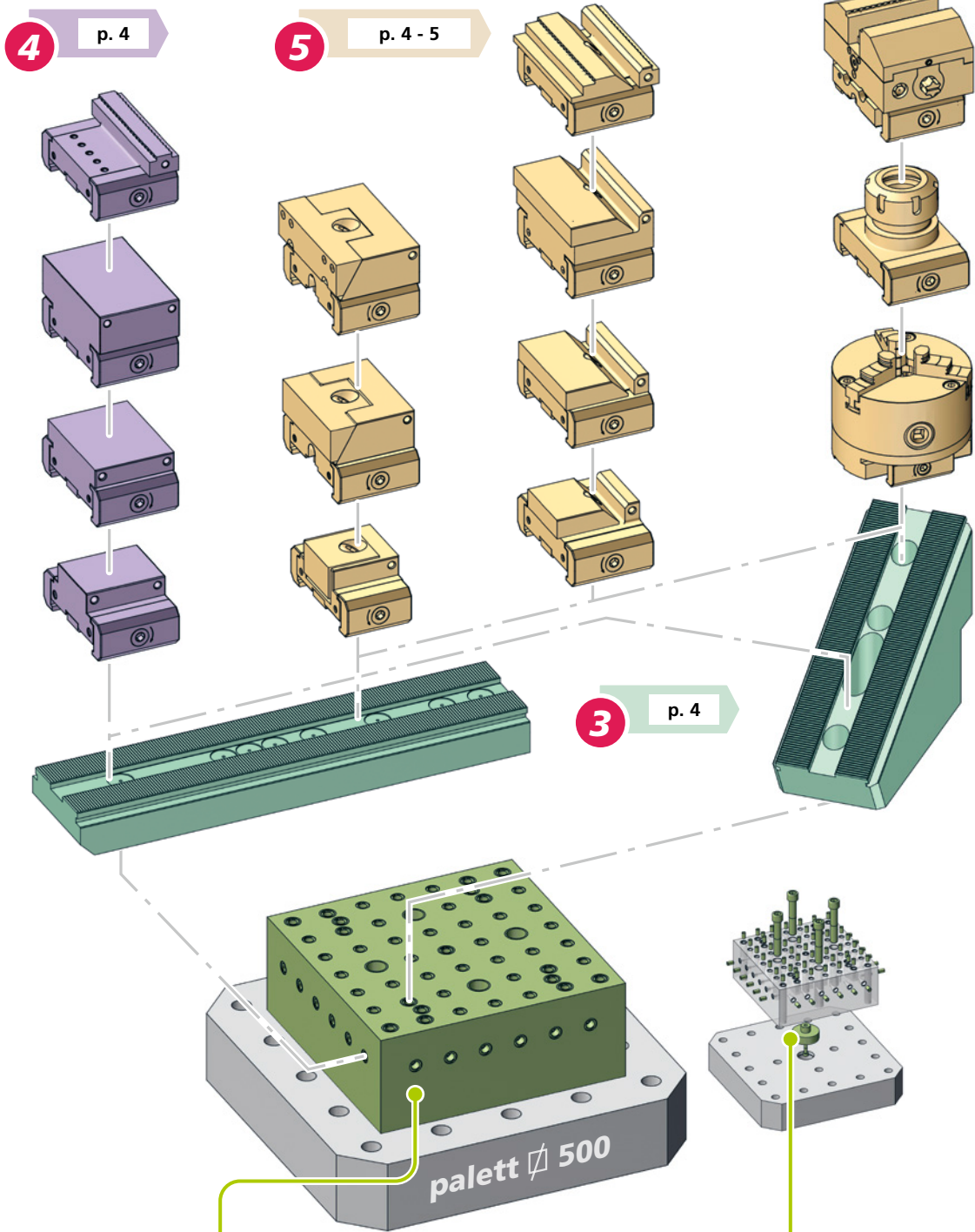

4 p. 4

5 p. 4 - 5

3 p. 4

1

2

MUB3535H140



Mineralguss Raster
Epoxy riser grid

BS-HCR5000S-1



Befestigungskit für
Mounting package
HCR5000S

Mazak



HCR5000S

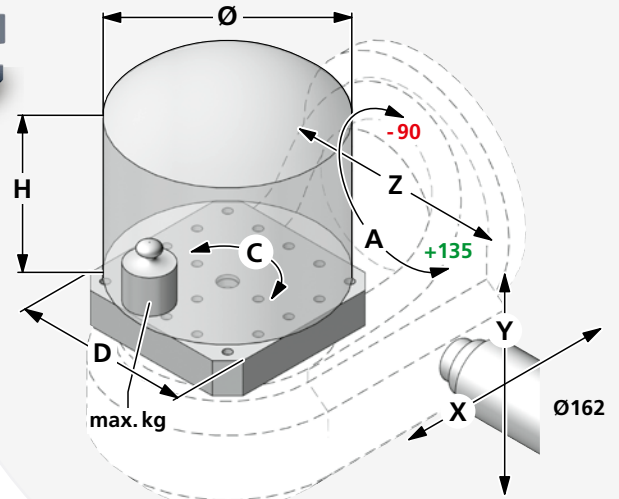
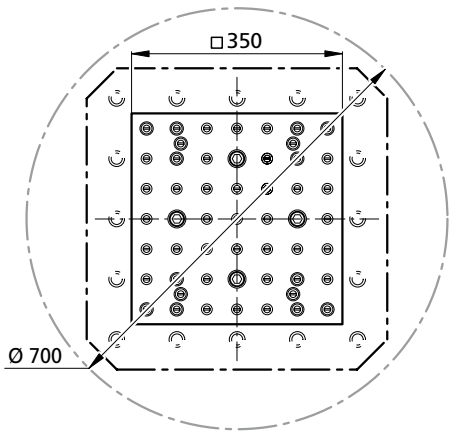
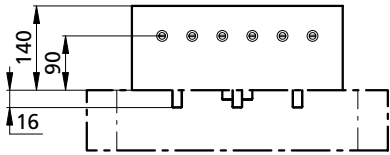

	X	Y	Z	A	C	max.		
						Ø	H	kg
HCR5000 S	730 (X-300 X+430)	730	730 (Z+100 Z+830)	-90° / +135	360°	700	643	500

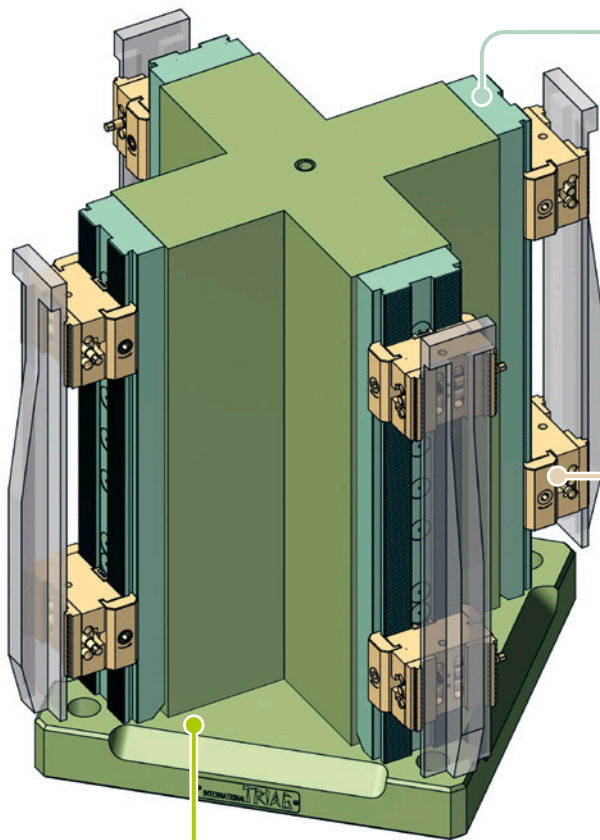

3 p. 4

5 p. 4 - 5

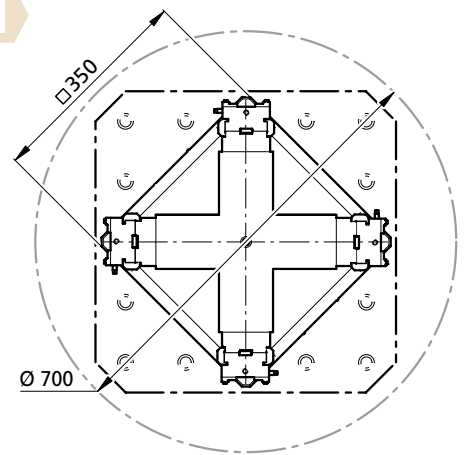
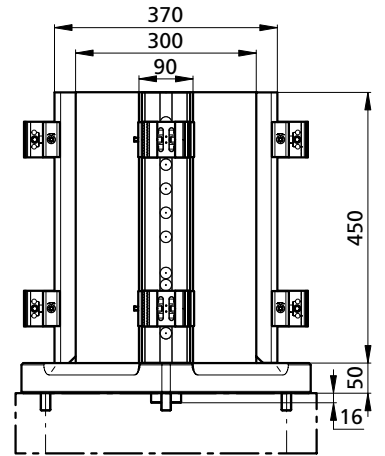

1

MK300945R50



Mineralgussturm
Epoxy mineral tombstone



HCR5000S



Stellen Sie Ihre eigenen Sets zusammen
Make your own sets

3 Basisschienen / Base-rails

PCB4050350 PCB4050450 PCB50207W27

4 Anschlagmodule / End modules

48		78		94	
PAND48-34	PAND48-49	PAND78-34	PAND78-49	PAND94-34	PAND94-49
		<ul style="list-style-type: none"> F = glatt / flat R = geriffelt / double serrated ☑ = Direktprägebacken / Direct stamping 			
PAND48-34PRF-A1	PAND48-49PRF-A1			PAND94-34PRF-A1	PAND94-49PRF-A1

5 Dreibackenfutter | Spannzangenmodul | Mini-Zentrischspanner
Three-jaw chuck | Collet module | Mini-self centering vise

PS3X125L87BSET	PS3X100L82BSET	PS3X80L75BSET	PS1X50N62-ER32	PCZ80L40PRG62	PCZ100L50

Inkl. 2 Backen
Incl. 2 jaws

SEPARAT BESTELLEN
SEPARATE ORDER p. 7

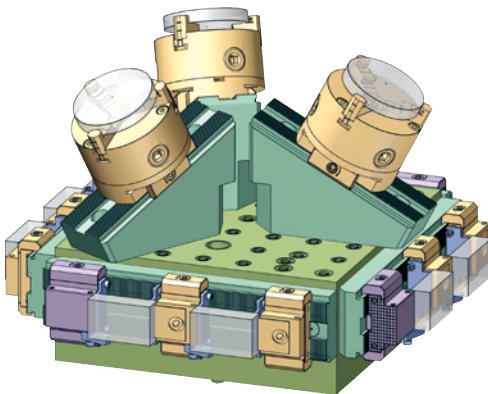

BESTELLBEISPIEL / ORDERING EXAMPLE

- | | | |
|----------------|----------------|-------------------|
| 1x MUB3535H140 | 3x PCB50207W27 | 9x PS3X125L87BSET |
| | 4x PCB4050350 | 8x PCSET18-N1 |
| 1 | 2 | 3 |
| 1x MZ5000S-S1 | 4x PAND48-34 | & 16 B48-29 |
| 4 | 5 | 6 |



Stellen Sie Ihre eigenen Sets zusammen
Make your own sets

5 Niedrigzugspannmodule / Pull down clamp modules

48		78		94	
PS1 R48N34 B80N 	PS1 R48N49 B80N 	PS1 R78N49 B90R78 	PS1 F48N49 B90F78 	PS1 R94N49 B90 	PS1 F94N49 B90
PCSET18-N1	PCSET18-N2	PCSET18-N5	PCSET18-N6	PCSET18-N7	PCSET18-N8
PS1 F48N34 B80N 	PS1 F48N49 B80N 	F = glatt / flat R = geriffelt / double serrated = Direktprägebacken / Direct stamping		PS1 R94N49 B93 	
PCSET18-N3	PCSET18-N4			PCSET18-N9	

Linearspannmodule / Linear clamp modules

PS1 PF 48L34 B115P 	PS1 PF 48L49 B115P 	PS1 R 78L34 B141 	PS1 F 78L34 B140 	PS1 PF 94L34 B120P 	PS1 PF 94L49 B120P
PCSET18-L1	PCSET18-L2	PCSET18-L5	PCSET18-L6	PCSET18-L9	PCSET18-L11
PS1 R 48L49 B106 	PS1 F 48L49 B105 	PS1 R 78L49 B141 	PS1 F 78L49 B140 	PS1 R 94L34 B111 	PS1 F 94L34 B110
PCSET18-L3	PCSET18-L4	PCSET18-L7	PCSET18-L8	PCSET18-L12	PCSET18-L13
PS1 R 48L34 B106 	PS1 F 48L34 B105 	Bei jedem Niedrigzug und Linear Spannmodul sind 2 Parallelunterlagen nach Ihrer Wahl inklusive 1 Fräsanschlag enthalten. 		PS1 R 94L49 B111 	PS1 F 94L49 B110
PCSET18-L16	PCSET18-L17	Each pull-down and linear clamping module includes 2 parallels of your choice and 1 milling buffer.		PCSET18-L14	PCSET18-L15

6 Parallelunterlagen / Steel parallels

48	78	94
PCU29047 H PCU 20 047 PCU 24 047 PCU29047 PCU 31 047 PCU 34 047 PCU 39 047 PCU 44 047 PCU 46 047 B48- ...	PCU39077 H PCU 20 077 PCU 24 077 PCU 29 077 PCU 31 077 PCU 34 077 PCU39077 PCU 44 077 PCU 46 077 B78- ...	PCU29093 H PCU 14 093 PCU 20 093 PCU 24 093 PCU29093 PCU 31 093 PCU 34 093 PCU 39 093 PCU 44 093 PCU 46 093 PCU 47 093 B94- ...
Fräsanschlag / Milling buffer FA1240 		1 x Inklusive / Included

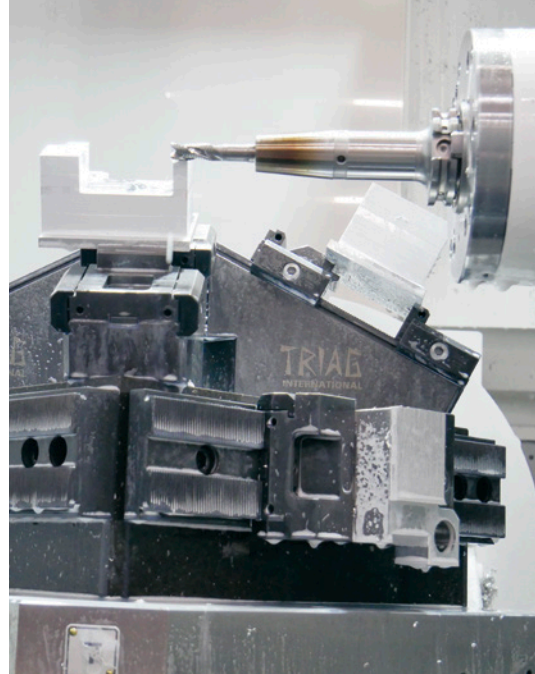

ANWENDUNGSBEISPIELE / APPLICATION EXAMPLES

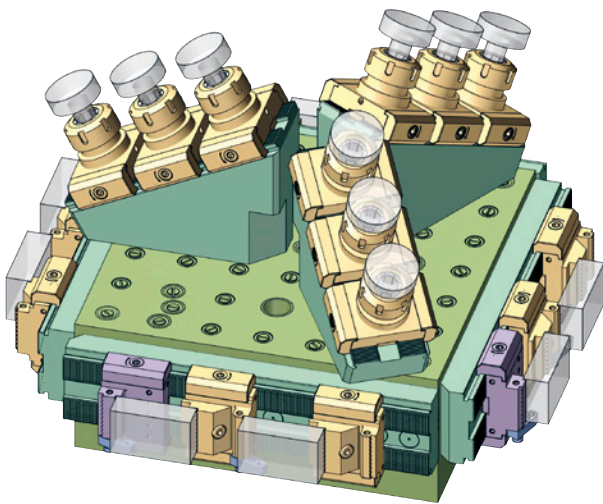

- 1x MUB3535H140
 - 3x PCB50207W27
 - 9x PS1X50N62-ER32
 - 4x PCB4050350
 - 8x PCSET18-L1
- 1 —
 2 —
 3 —
 4 —
 5 —
 6
- 1x MZ5000S-S1
 - 4x PAND48-34PRF-A1
 - & 16 B48-29

- 1x MUB3535H140
 - 4x PCB50207W27
 - 4x PS3X125L87BSET
 - 4x PCB4050350
 - 8x PCSET18-N6
- 1 —
 2 —
 3 —
 4 —
 5 —
 6
- 1x MZ5000S-S1
 - 4x PAND78-49
 - & 16 B78-39

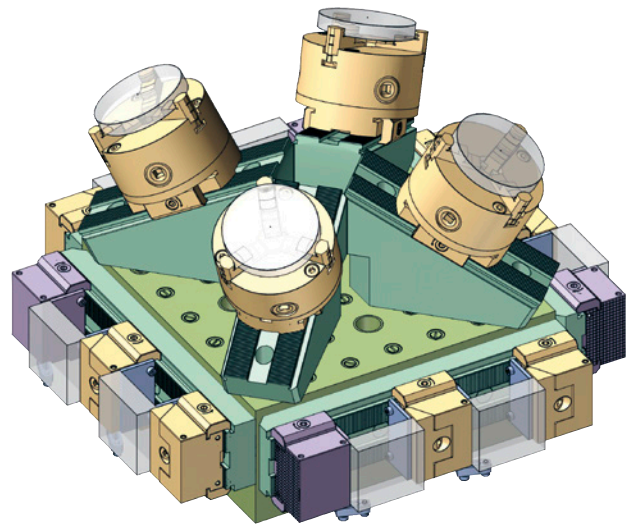

- 1x MUB3535H140
 - 3x PCB50207W27
 - 6x PCZ100L50
 - 4x PCB4050350
 - 8x PCSET18-L15
 - 12x B175-26
- 1 —
 2 —
 3 —
 4 —
 5 —
 6
- 1x MZ5000S-S1
 - 4x PAND94-49
 - & 16 B94-39

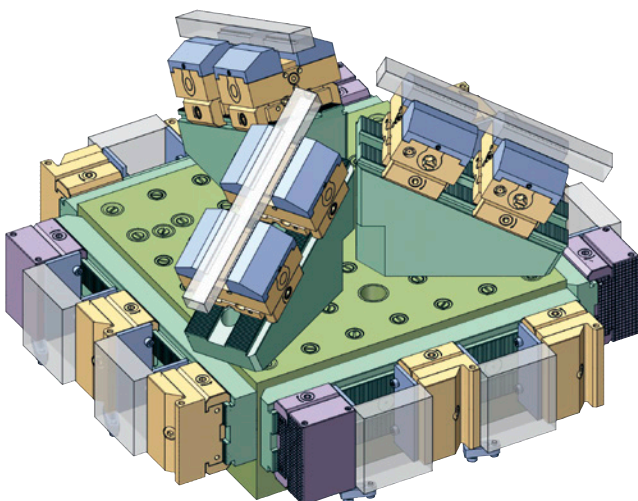

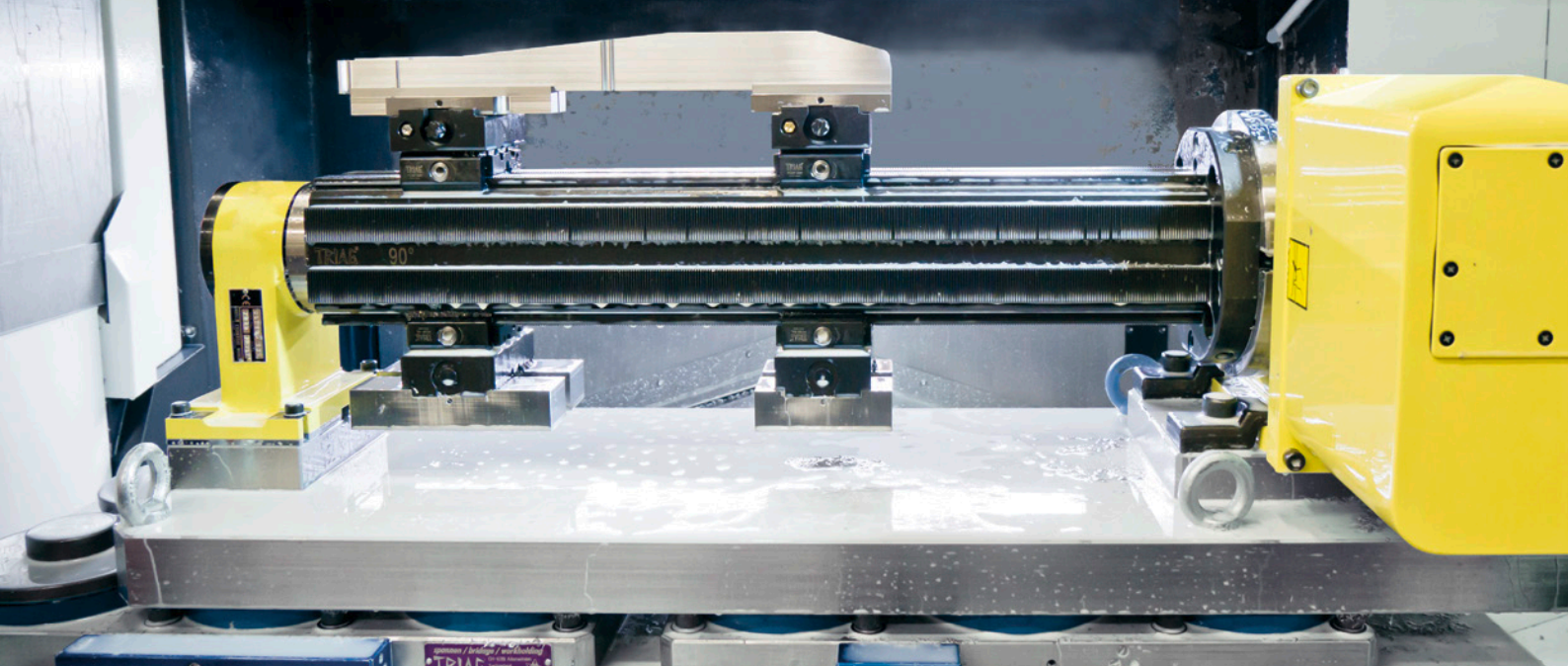

p. 4

max. 50 Nm
TX 30E14

25 Nm

2x

MINI PCZ100L50

Backen zu Mini Zentrischspanner
Jaws for mini self centering vise

Spannbereich / Clamping range		Spannbereich / Clamping range		Spannbereich / Clamping range		Spannbereich / Clamping range	
B175-26	6 - 26 mm	B175-45	25 - 45 mm	B175-64	44 - 64 mm	B170, B172 (weich/soft) 0 - 20 mm	
i 57HRC		i 57HRC		i 57HRC		i HV700x0,2mm	
Spannbereich / Clamping range		Spannbereich / Clamping range		Spannbereich / Clamping range		Zum Erstellen Ihrer individuellen Formbacke: Maximalen Bearbeitungsprofiltiefe If a dedicated jaw is being machined: Max. workpiece machining depth 	
B175-83	63 - 83 mm	B175-102	82 - 102 mm	B175-121	101 - 121 mm		
i 57HRC		i 57HRC		i 57HRC			
Spannbereich / Clamping range		Spannbereich / Clamping range		Spannbereich / Clamping range		Spannbereich / Clamping range	
B173-26	6 - 26 mm	B173-45	25 - 45 mm	B173-64	44 - 64 mm	B176-80 8 - 80 mm	
i HV700x0,2mm		i HV700x0,2mm		i HV700x0,2mm		i HV700x0,2mm	
Spannbereich / Clamping range		Spannbereich / Clamping range		PRG1003M8 Optional erhältlich Optional accessory 			
B173-83	63 - 83 mm	B173-102	82 - 102 mm				
i HV700x0,2mm		i HV700x0,2mm					

Drehmoment Torque		Spannkraft Workholding force	
10 Nm	lb-ft 7,4	= 0,2 t	200 daN
20 Nm	lb-ft 14,8	= 0,5 t	500 daN
30 Nm	lb-ft 22,2	= 1,0 t	1'000 daN
40 Nm	lb-ft 29,6	= 1,3 t	1'300 daN
50 Nm	lb-ft 37,0	= 1,6 t	1'600 daN

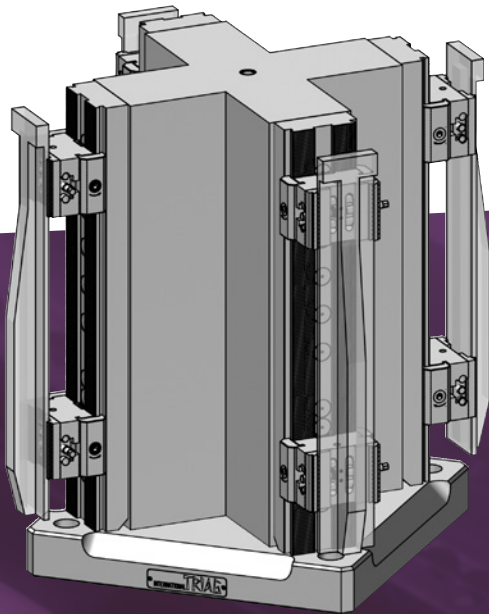
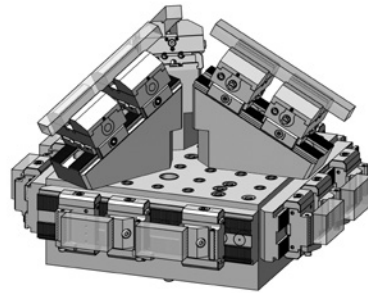
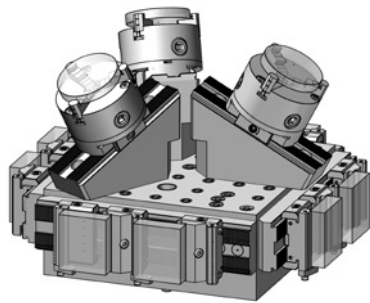

Triag International AG

Bösch 84 CH-6331 Hünenberg

☎ +41 41 727 27 77

✉ spannen@triag-int.ch

✉ clamping@triag-int.ch

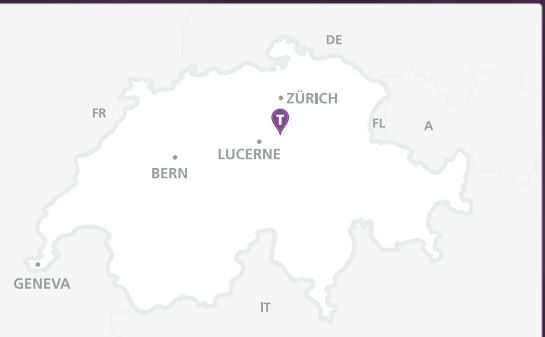

Mass- und Konstruktionsänderungen
bleiben uns vorbehalten. *We reserve
the right to modify dimensions and
structural design.*

triag-int.ch

Official Website



11
22